

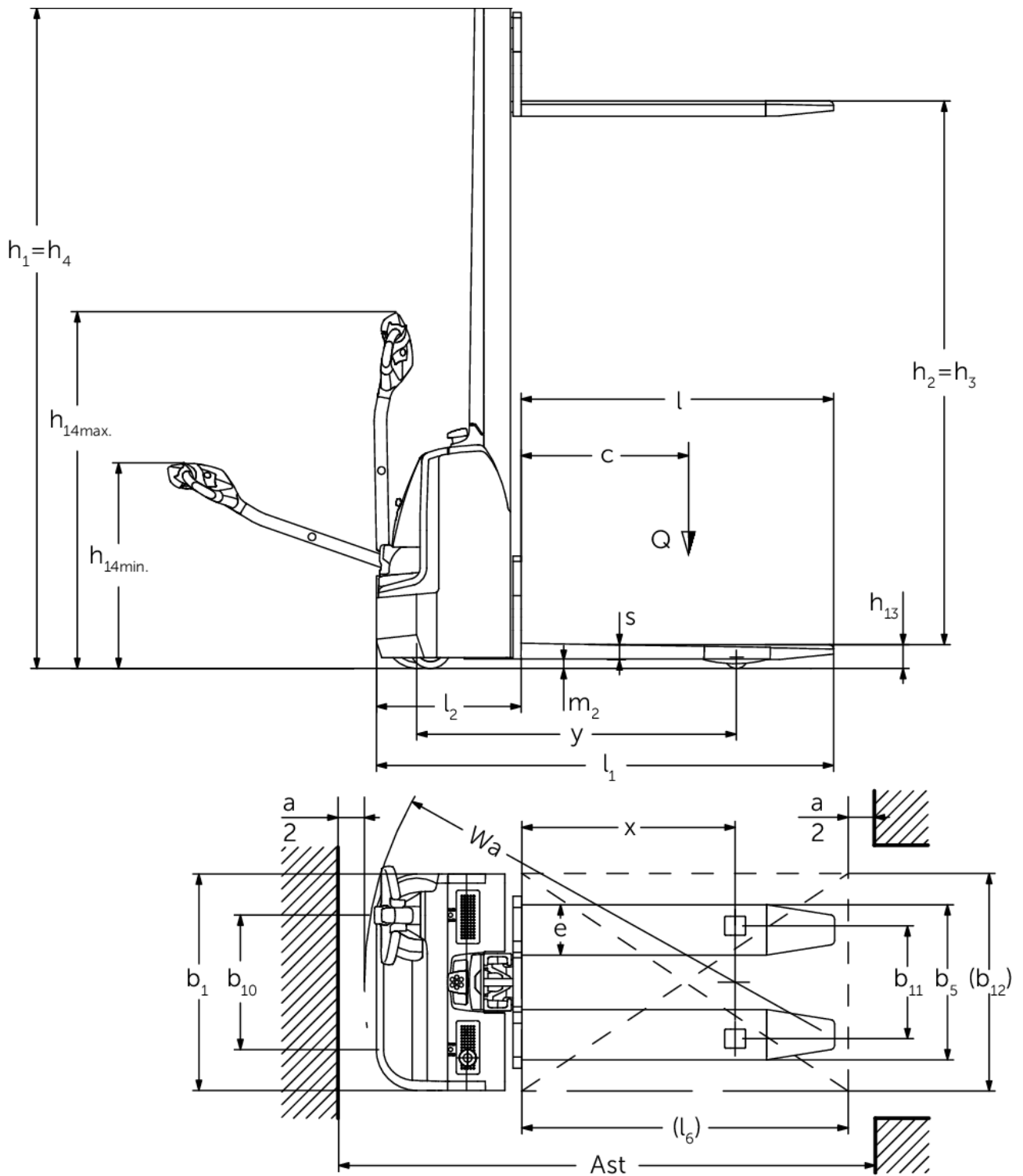

Electric pedestrian stacker **EMC 105 / 110 / 110 RK / B10**

Lift height: 1540 mm / Load capacity: 1000 kg

EMC 105 / 110 / 110 RK / B10



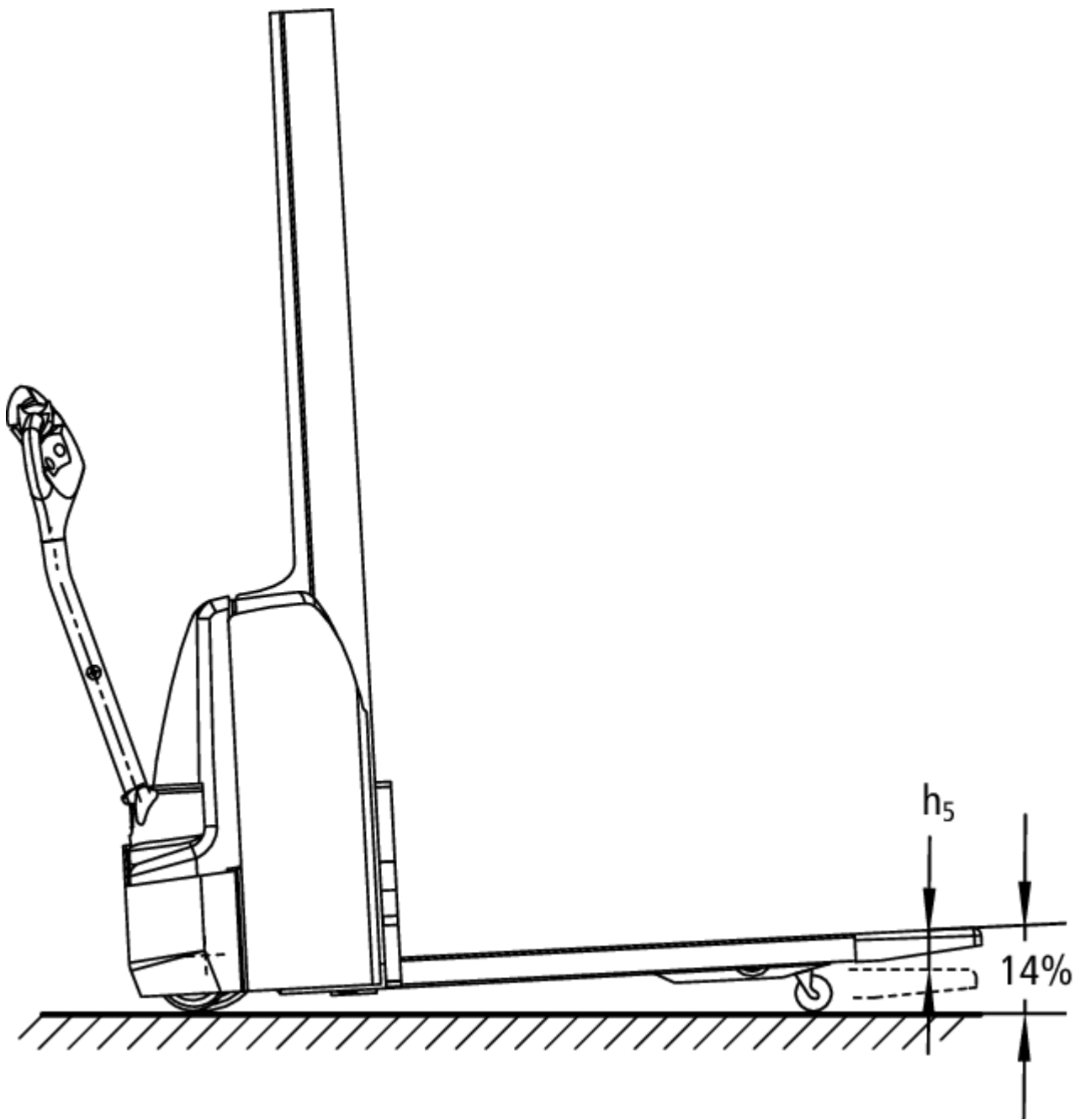

EMC 105 / 110 / 110 RK / B10



EMC 105 / 110 / 110 RK / B10

, EMC 110 , EMC 110 with ramp comfort, EMC B10	Lift (h3)	Retracted mast height (h1)	Free lift (h2)	Extended mast height (h4)
	1540 mm	1970 mm	1540 mm	1970 mm
	2000 mm	2430 mm	2000 mm	2430 mm

VDI table

Stand-on: 10/2020

Characteristic	1.1	Manufacturer (abbreviated description)	Jungheinrich					
	1.2	Manufacturer's type designation	EMC 105	EMC 110	EMC 110 ramp comfort	EMC B10		
Characteristic	1.3	Drive	Electric					
	1.4	Operation	Pedestrian/tiller		Pedestrian	Pedestrian/tiller		
	1.5	Load capacity/load	Q kg	500	1000			
	1.6	Load centre distance	c mm	600				
	1.8	Load distance, centre of drive axle to fork	x mm	764	784			
	1.9	Wheelbase	y mm	1149	1168			
	Weights	2.1.1	Service weight (incl. battery)	kg	460	490	510	535
2.2		Axle load laden front/rear	kg	465 / 485	500 / 990	510 / 1000		530 / 1005
2.3		Axle load unladen front/rear	kg	330 / 130	350 / 140	360 / 150		390 / 145
Wheels/suspension system	3.1	Tyres	PU					
	3.2	Tyre size, front	Ø 230 x 70					
	3.3	Tyre size, rear	Ø 38 x 60	Ø 77 x 70 / Ø 77 x 50	Ø 85x85	Ø 77 x 75 / Ø 77 x 50		
	3.4	Additional wheels	Ø 150 x 54			Ø 140x 54		
	3.5	Wheels, number front/back (x=driven)	1x +1 / 4	1x +1/2				
	3.6	Tread width, front	b ₁₀ mm	510				
	3.7	Tread width, rear	b ₁₁ mm	365	415		1000	
	3.7.1	2. Tread width, rear	mm	-			1170	
3.7.2	3. Tread width, rear	mm	-			1370		
Basic dimensions	4.2	Retracted mast height (h1)	h ₁ mm	1970				
	4.3	Free lift (h2)	h ₂ mm	1588	1540			
	4.4	Lift (h3)	h ₃ mm	1588	1540			
	4.5	Extended mast height (h4)	h ₄ mm	1970				
	4.9	Height of tiller handle in drive position min./ max.	mm	821 / 1305				
	4.15	Height, lowered	h ₁₃ mm	40	88			
	4.19	Overall length	l ₁ mm	1685				
	4.20	Length including fork shank	l ₂ mm	535				
	4.21.1	Overall width	b ₁ mm	800				
	4.21.2	Overall width	b ₂ mm	-		1100		
	4.22	Fork dimensions	s/ e/l mm	34 / 185 / 1150	56 / 185 / 1150			
	4.25	Width across forks	b ₅ mm	550	570			
	4.32	Ground clearance centre of wheelbase	m ₂ mm	8	30	40		
	4.34	Aisle width (pallet 1000x1200 sideways)	Ast mm	2247	1945			
	4.34.1	Aisle width (pallet 800x1200 length)	Ast mm	2125	1995			
4.35	Turning radius	W _a mm	1334	1378				
Performance data	5.1	Travel speed laden/unladen	km/h	4.2 / 5				
	5.2	Lift speed laden/unladen	m/s	0.09 / 0.16				
	5.3	Lowering speed laden/unladen	m/s	0.12 / 0.13				
	5.7	Gradeability laden/unladen	%	3.5 / 15				
	5.10	Service brake		generative				

E-motor/Electronics	6.1	Drive motor, performance S2 60 min	kW	0.5		
	6.2	Lift motor, performance with S3	kW	1.5		
	6.3	Battery according to DIN 43531/35/36		no		
	6.4	Battery voltage/nominal capacity	V / Ah	12 / 70		
	6.5	Battery weight	kg	63		
	6.6	Energy consumption according to VDI cycle	kWh/h	0	0.55	0
	6.6.1	Energy consumption according to EN cycle	kWh/h	0.4	-	0.4
	6.6.2	CO2 equivalent as per EN 16796	kg/h	0.2	0	0.2
Other	8.1	Type of drive control		AC		
	10.7	Sound level as per EN12053, operator's ear	dB (A)	70		

- This data sheet according to VDI guideline 2198 only states the technical values of the standard truck. Different tyres, other masts, additional equipment etc. may result in different values.

- 4.2: For EMC 112 RK diagonal as per VDI: + 159 mm - 4.3: For EMC 112 RK diagonal as per VDI: + 159 mm - 4.4: For EMC 112 RK diagonal as per VDI: + 159 mm - 4.5: For EMC 112 RK diagonal as per VDI: + 159 mm - 4.33: For EMC 112 RK diagonal as per VDI: + 262 mm - 4.34: For EMC 112 RK with version with tall mast: + 460 mm

The German production facilities in
Norderstedt, Moosburg and Landsberg
are certified.

ISO 9001
ISO 14001

Jungheinrich fork lift trucks meet
European safety requirements.



 **JUNGHEINRICH**

The Jungheinrich logo, featuring a red upward-pointing arrow integrated into the letter 'J', followed by the word 'JUNGHEINRICH' in a bold, black, sans-serif font.