



Scissor lift hand pallet truck **AMX 10 / 10e**

Lift height: 714 mm / Load capacity: 1000 kg

JUNGHEINRICH

AMX 10 / 10e

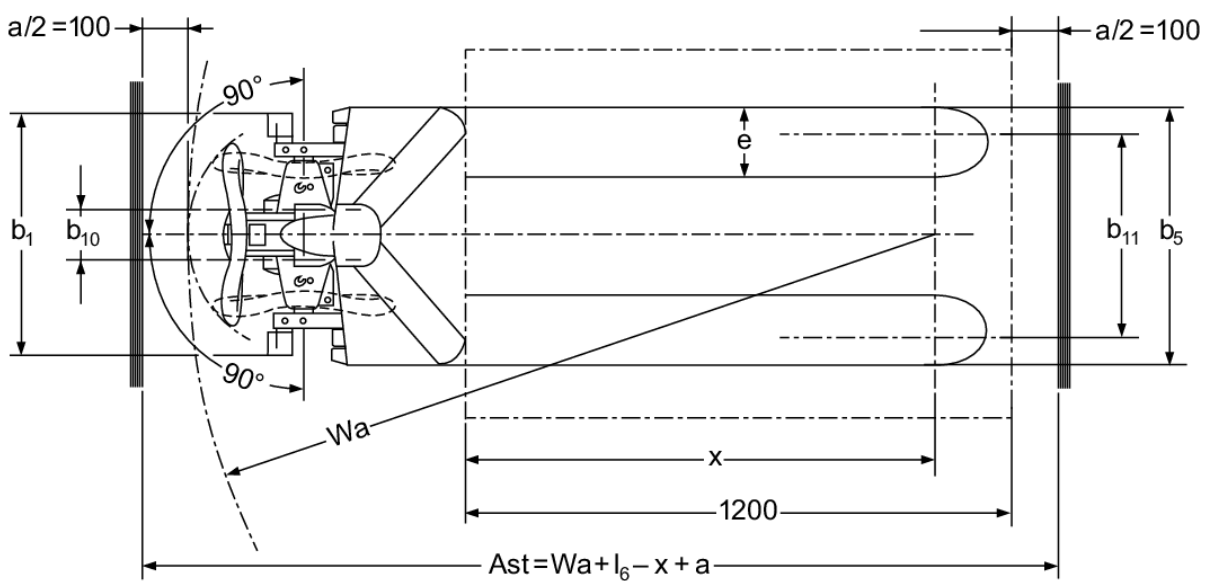
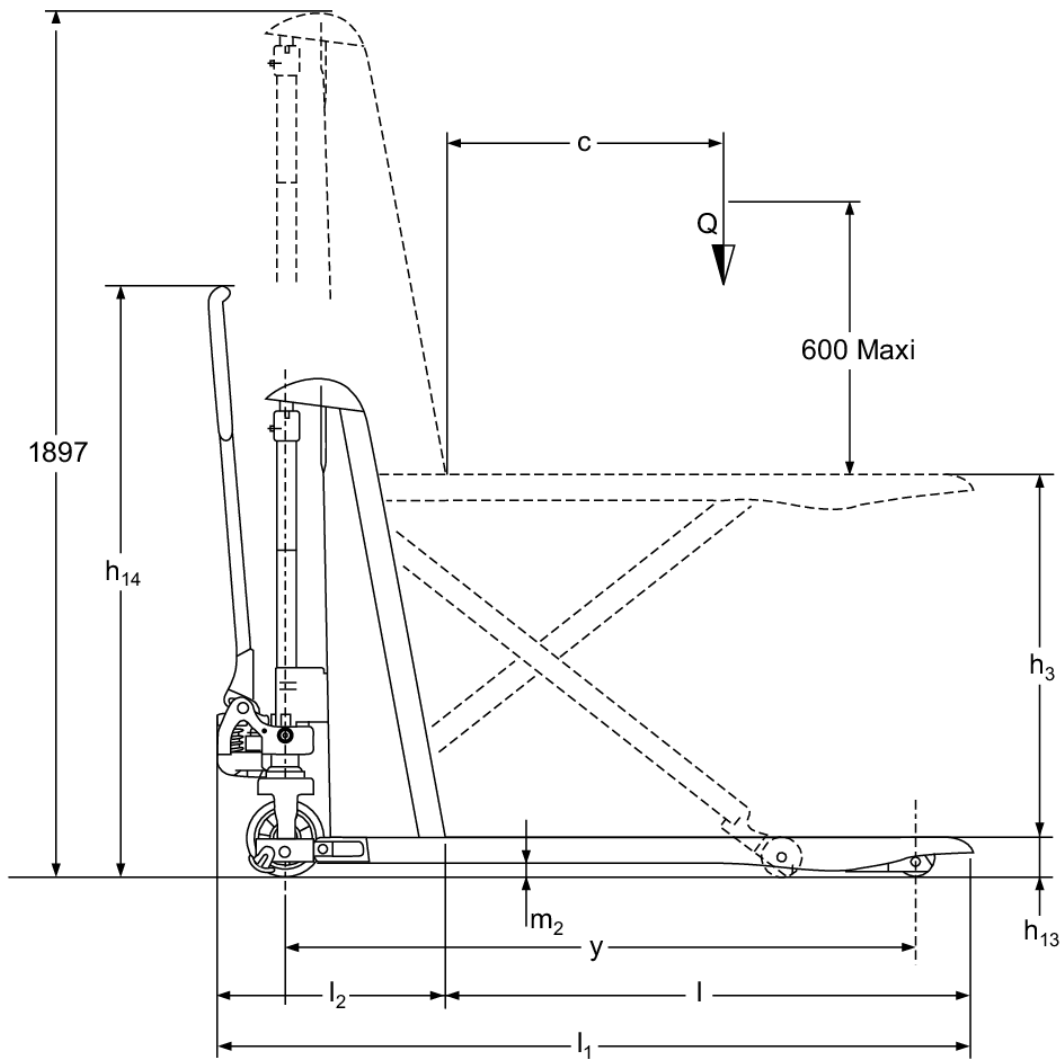

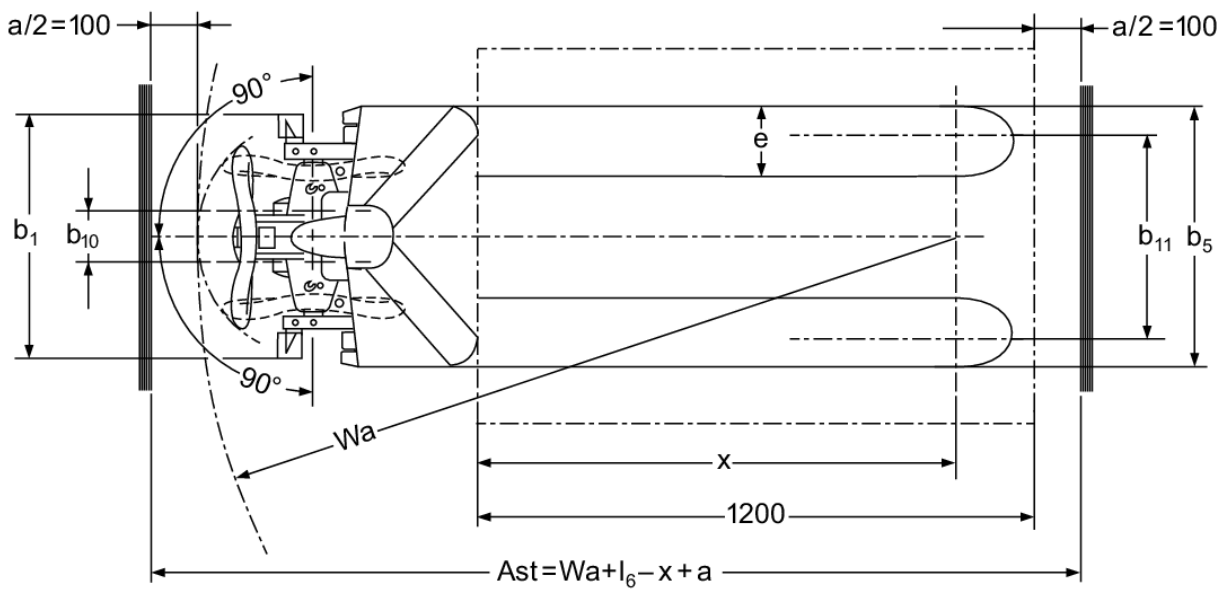
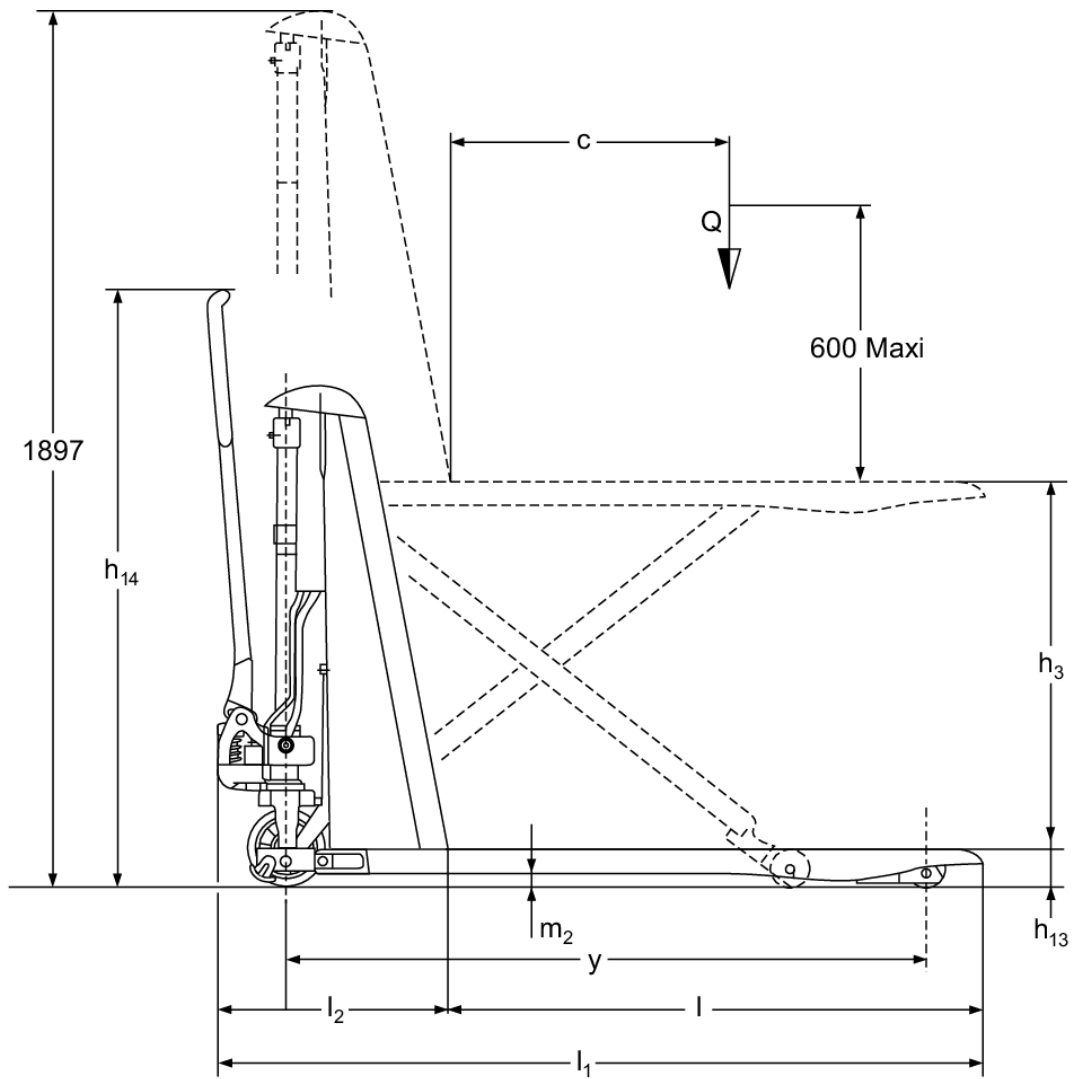

VDI table

Stand-on: 02/2021

Characteristic	1.1	Manufacturer (abbreviated description)	Jungheinrich					
	1.2	Manufacturer's type designation	AMX 10e		AMX 10			
	1.3	Drive	Electric	Manual				
	1.4	Operation	Manual					
	1.5	Load capacity/load	Q kg	1000				
	1.6	Load centre distance	c mm	600				
	1.9	Wheelbase	y mm	1383	-	1383	-	
Weights	2.1	Service weight	kg	195		157		
	2.2	Axle load laden front/rear	kg	443 / 752	-	406 / 751	-	
	2.3	Axle load unladen front/rear	kg	136 / 59	-	101 / 56	-	
Wheels/suspension system	3.1	Tyres		N, C, V	Nylon	R + R	N, C, V	R + R
	3.2	Tyre size, front		Ø 170 x 50		-	Ø 170 x 50	-
	3.3	Tyre size, rear		Ø 82 x 62		-	Ø 82 x 62	-
	3.5	Wheels, number front/back (x=driven)		2/2		-	2/2	-
	3.6	Tread width, front	b ₁₀ mm	109		-	109	-
	3.7	Tread width, rear	b ₁₁ mm	440		-	440	-
	Basic dimensions	4.4	Lift (h ₃)	h ₃ mm	714			
4.5		Extended mast height (h ₄)	h ₄ mm	1897	-	1897	-	
4.9		Height of tiller handle in drive position min./max.	mm	1299 /	-	1299 /	-	
4.15		Height, lowered	h ₁₃ mm	86				
4.19		Overall length	l ₁ mm	1650	-	1650	-	
4.20		Length including fork shank	l ₂ mm	500	-	500	-	
4.21.1		Overall width	b ₁ mm	560	-	560	-	
4.22		Fork dimensions	s/e/l mm	53 / 150 / 1150	150 / 1150	53 / 150 / 1150	150 / 1150	
4.25		Width across forks	b ₅ mm	560	680	560	680 560 680	
4.32		Ground clearance centre of wheelbase	m ₂ mm	30	-	30	-	
4.34.1		Aisle width (pallet 800x1200 length)	Ast mm	2005	-	2005	-	
4.35	Turning radius	W _a mm		-	1635	-		
Performance data	5.3	Lowering speed laden/unladen	m/s	0.13 / 0.05	-	0.11 / 0.04	-	
E-motor/ Electronics	6.2	Lift motor, performance with S3	kW	0.5		-		
	6.4	Battery voltage/nominal capacity	V / Ah	12 / 70		-		
	6.5	Battery weight	kg	24	-			

- This data sheet according to VDI guideline 2198 only states the technical values of the standard truck. Different tyres, other masts, additional equipment etc. may result in different values.

The German production facilities in
Norderstedt, Moosburg and Landsberg
are certified.

ISO 9001
ISO 14001

Jungheinrich fork lift trucks meet
European safety requirements.



 **JUNGHEINRICH**