



Electric pedestrian pallet truck with picking lift

EJE C20

Lift height: 540 mm / Load capacity: 2000 kg

EJE C20

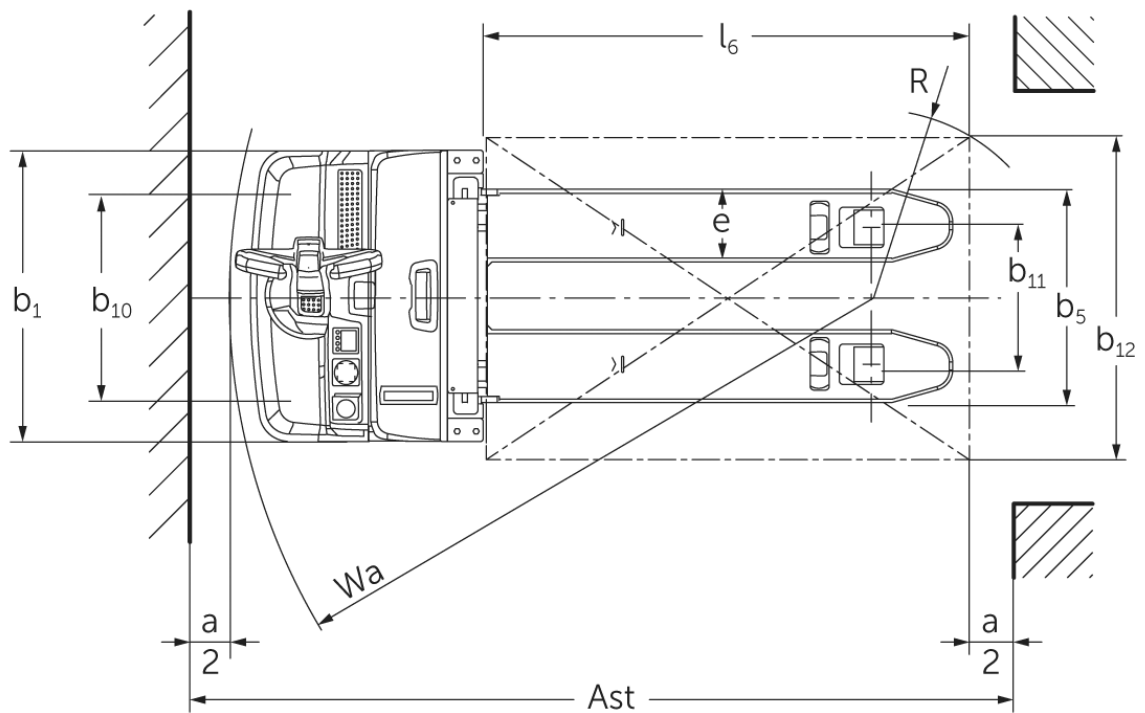
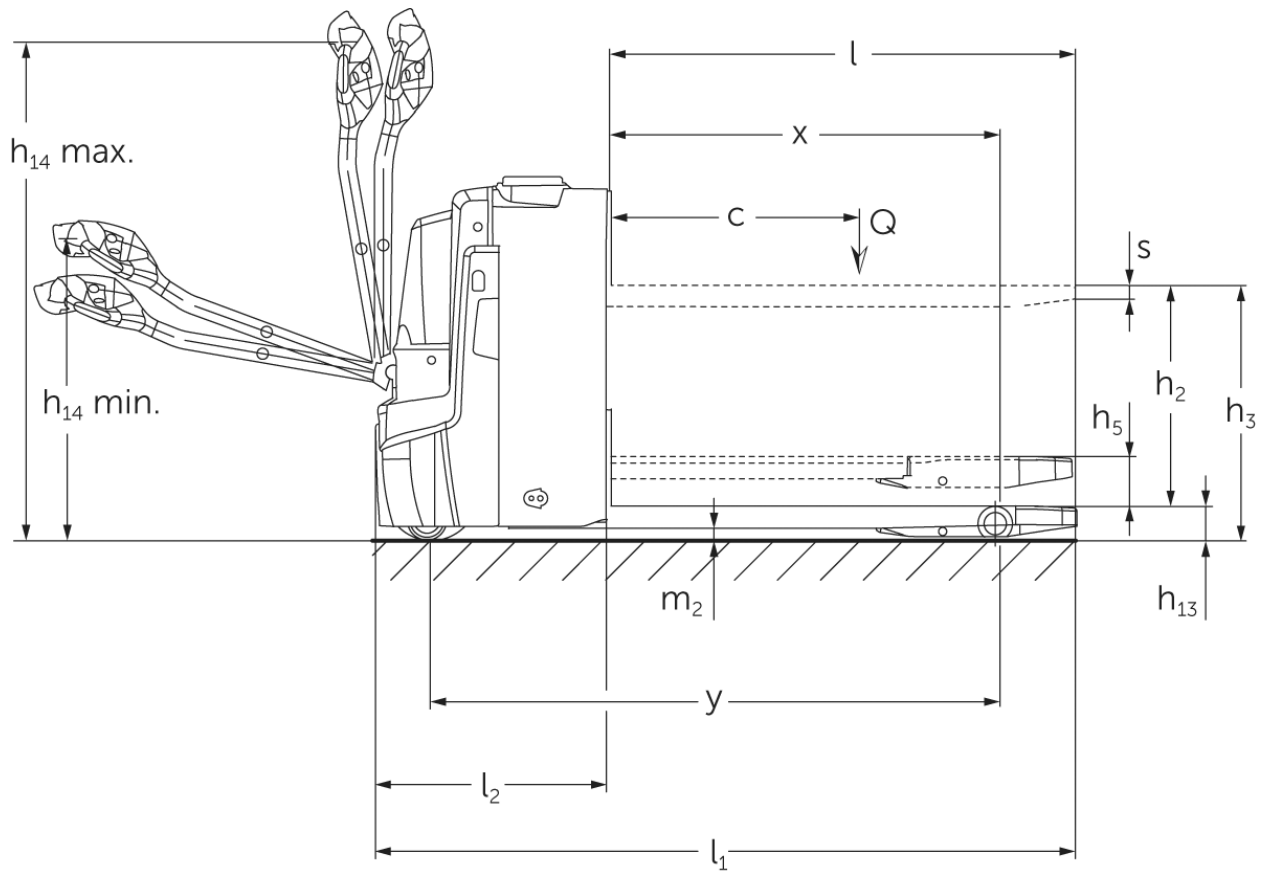

VDI table

Stand-on: 10/2020

Characteristic	1.1	Manufacturer (abbreviated description)		Jungheinrich	
	1.2	Manufacturer's type designation		EJE C20	
	1.3	Drive		Electric	
	1.4	Operation		Pedestrian	
	1.5	Load capacity/load	Q	kg	2000
	1.5.1	Rated capacity/load with mast lift	Q	kg	700
	1.6	Load centre distance	c	mm	600
	1.8	Load distance, centre of drive axle to fork	x	mm	893
	1.9	Wheelbase	y	mm	1333
Weights	2.1.1	Service weight (incl. battery)		kg	523
	2.2	Axle load laden front/rear		kg	800 / 1729
	2.3	Axle load unladen front/rear		kg	390 / 133
Wheels/suspension system	3.1	Tyres			PU/PU
	3.2	Tyre size, front			Ø 230 x 70
	3.3	Tyre size, rear			Ø 85 x 95
	3.4	Additional wheels			Ø 100 x 40
	3.5	Wheels, number front/back (x=driven)			1x +2/2 oder 4
	3.6	Tread width, front	b ₁₀	mm	510
	3.7	Tread width, rear	b ₁₁	mm	338
Basic dimensions	4.3	Free lift (h ₂)	h ₂	mm	540
	4.4	Lift (h ₃)	h ₃	mm	752
	4.6	Initial lift	h ₅	mm	122
	4.9	Height of tiller handle in drive position min./max.		mm	750 / 1237
	4.15	Height, lowered	h ₁₃	mm	90
	4.19	Overall length	l ₁	mm	1734
	4.20	Length including fork shank	l ₂	mm	584
	4.21.1	Overall width	b ₁	mm	720
	4.22	Fork dimensions	s/e/l	mm	60 / 180 / 1150
	4.25	Width across forks	b ₅	mm	530
	4.32	Ground clearance centre of wheelbase	m ₂	mm	30
	4.34	Aisle width (pallet 1000x1200 sideways)	Ast	mm	2322
	4.34.1	Aisle width (pallet 800x1200 length)	Ast	mm	2217
	4.35	Turning radius	W _a	mm	1513
Performance data	5.1	Travel speed laden/unladen		km/h	6 / 6
	5.2	Lift speed laden/unladen		m/s	00
	5.3	Lowering speed laden/unladen		m/s	00
	5.8	Max. gradeability laden/unladen		%	8 / 20
	5.10	Service brake			generative
E-motor/Electronics	6.1	Drive motor, performance S2 60 min		kW	1.1
	6.2	Lift motor, performance with S3		kW	1.2
	6.4	Battery voltage/nominal capacity		V / Ah	24 / 150
	6.5	Battery weight		kg	151
	6.6	Energy consumption according to VDI cycle		kWh/h	0
	6.6.1	Energy consumption according to EN cycle		kWh/h	0.31
	6.6.2	CO2 equivalent as per EN 16796		kg/h	0.2
	6.7	Throughput		t/h	100

	6.8.1	Energy consumption with max. throughput	kWh/h	0.63
Other	8.1	Type of drive control		AC
	10.7	Sound level as per EN12053, operator's ear	dB (A)	61
<p>- This data sheet according to VDI guideline 2198 only states the technical values of the standard truck. Different tyres, other masts, additional equipment etc. may result in different values.</p>				

- 4.34: Load section lowered: + 24 mm - 4.33 Load section lowered: + 49 mm - 1.8: 1.9: 4.35: Load section lowered: + 56 mm

The German production facilities in
Norderstedt, Moosburg and Landsberg
are certified.

ISO 9001
ISO 14001

Jungheinrich fork lift trucks meet
European safety requirements.



 **JUNGHEINRICH**

The logo features a red upward-pointing arrow integrated into the letter 'J' of the word 'JUNGHEINRICH', which is written in a bold, black, sans-serif font.